

Robotics competition for teenagers

The French School Victor-Hugo in Frankfurt organize a robotics competition on Wednesday, May the 22th 2024, at the school. (Address : Gontardstr. 11, 60488 Frankfurt am Main.)

The challenge consists in designing and making a mobile robot able to run in a minimal time and in complete autonomy a pre-determined track.



- **Two tracks are available**, one mobile being authorized to compete on one track only.
- The mobile robots will have to be fitted with a body on the theme « Paris 2024 », which will be rewarded with a special design prize.
- The students, in teams of 3 to 5 persons, will have to argue the technical solutions they have considered and those they have chosen. For this purpose, they will provide a technical file -digital or paper- with the following parts :
 - Step 1 - appropriation of the specification
 - Step 2 – research for the solutions
 - Step 3 – realization and tests
 - Step 4 – final presentation.
- **Attending a competition in a multicultural context.** The day of the competition (05/22/2024), the major language spoken will be French, however German and English will also be used to the benefit of each teams.

Technical files can be presented in either French, German or English.

Calendar

The first year of the competition, 150 students have taken part and last year we had 300. As we have a limited accommodation capacity and we wish for a maximum of schools to participate, we decided this year to use a pre-registration system.

From September, 15th 2023

Application files :

- By email with the last page of this document (see below) completed: christophe.bouvet@lfvh.net

From December, 4ⁿd 2023

Applications approval. We commit to welcome all the schools who have been pre-registered. Depending on the number of competitors, we will perhaps have to limit the number of people from each schools but it will only be after debate with those schools. We will be able to host the students in the French school families depending on their capacities.

For any questions, contact Christophe Bouvet: christophe.bouvet@lfvh.net

May, 22th 2024

Day of the competition

Rules of the challenges

Article 1. Technical constraints.

The project has to answer the following constraints :

- Maximal dimensions of the mobile are noted on each challenge and have to be respected (cf. article 2).
- The mobile has to be fitted with :
 - a body on the theme « Paris 2024 »,
 - a system of switch-on and off.
- The mobile has to move autonomously without any remote controller.
- The combustion engines are forbidden.
- The mobile must keep a direct contact with the ground. (no flying / hovering / jumping, etc)
- Models from shops and modular elements (Lego, Fischer Technik, etc.) are accepted but we recommend to join this adventure with your own unique and original creation.

Article 2. Challenges

Reminder : Mobiles will be registered to only one of the following challenges. Theme for the body is « Paris 2024 ».

Challenge 1 : Line tracker

This challenge consists in achieving a path materialized by a black line on a white font. A bascule bridge/ a scale must be crossed with an inclination of 7.6 degrees (see plan below). The maximal dimensions for the board are 3 meters on 3 (a square).

The line is continue, large of 5 cm, and the radii of curvature have a minimum of 10 cm. The line is present at the start of the board. The end line is materialized with a 5 cm large black band, perpendicular to the course line. During the challenge, the mobile is allowed to deviate from the black line if it then returns to it. The mobile has to completely cross the end line and stop in the following 30 cm. At that point there is no more a course line.

Maximum size of the mobile

Weight : 25 cm maximum

Length : 25 cm maximum

Height : 40 cm maximum

Path board

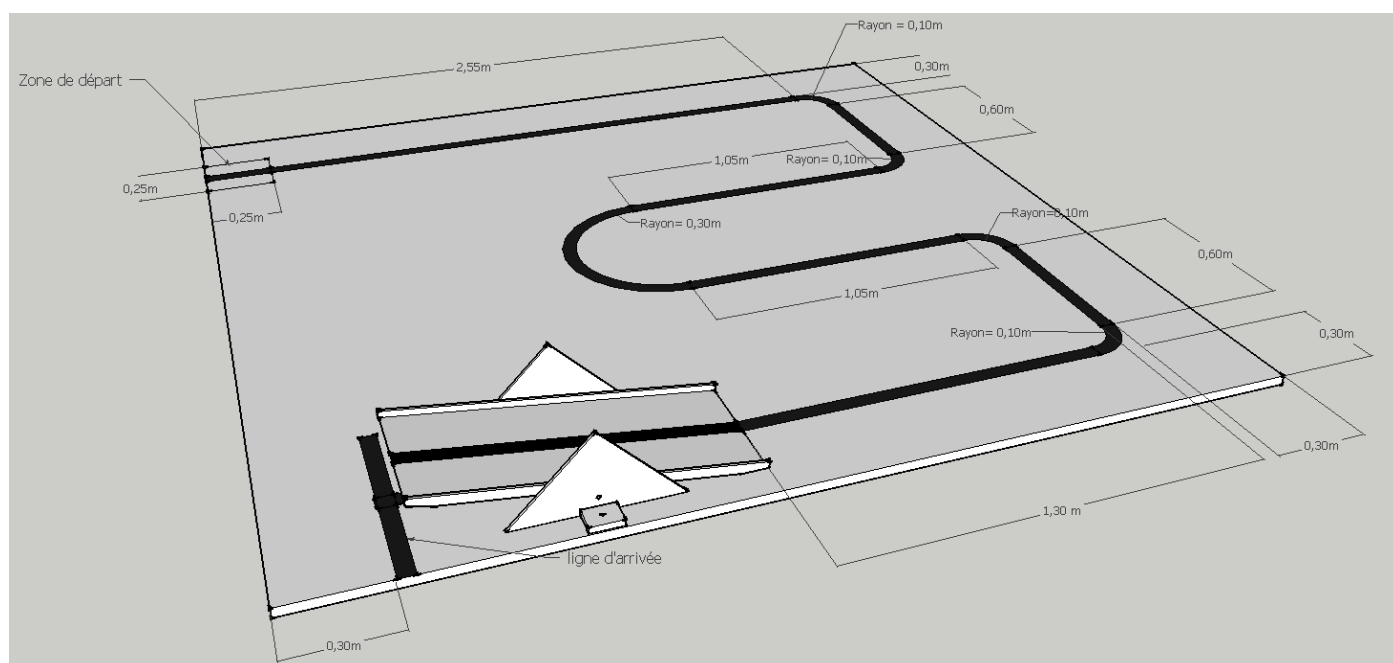

View from above challenge 1

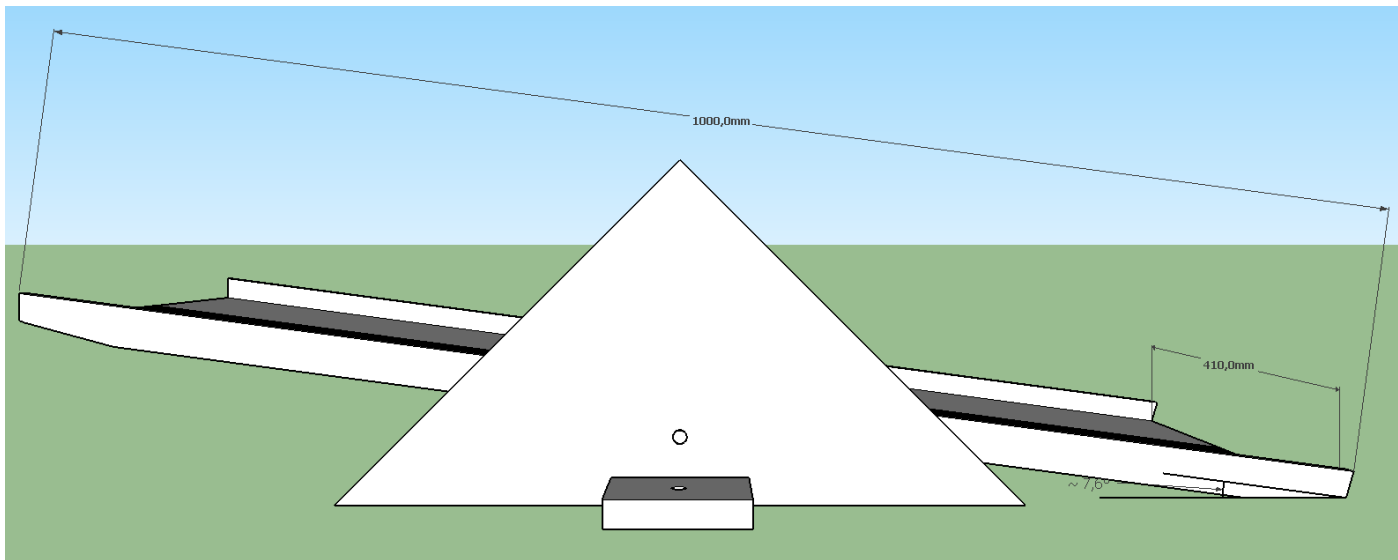

Right view of the bascule bridge

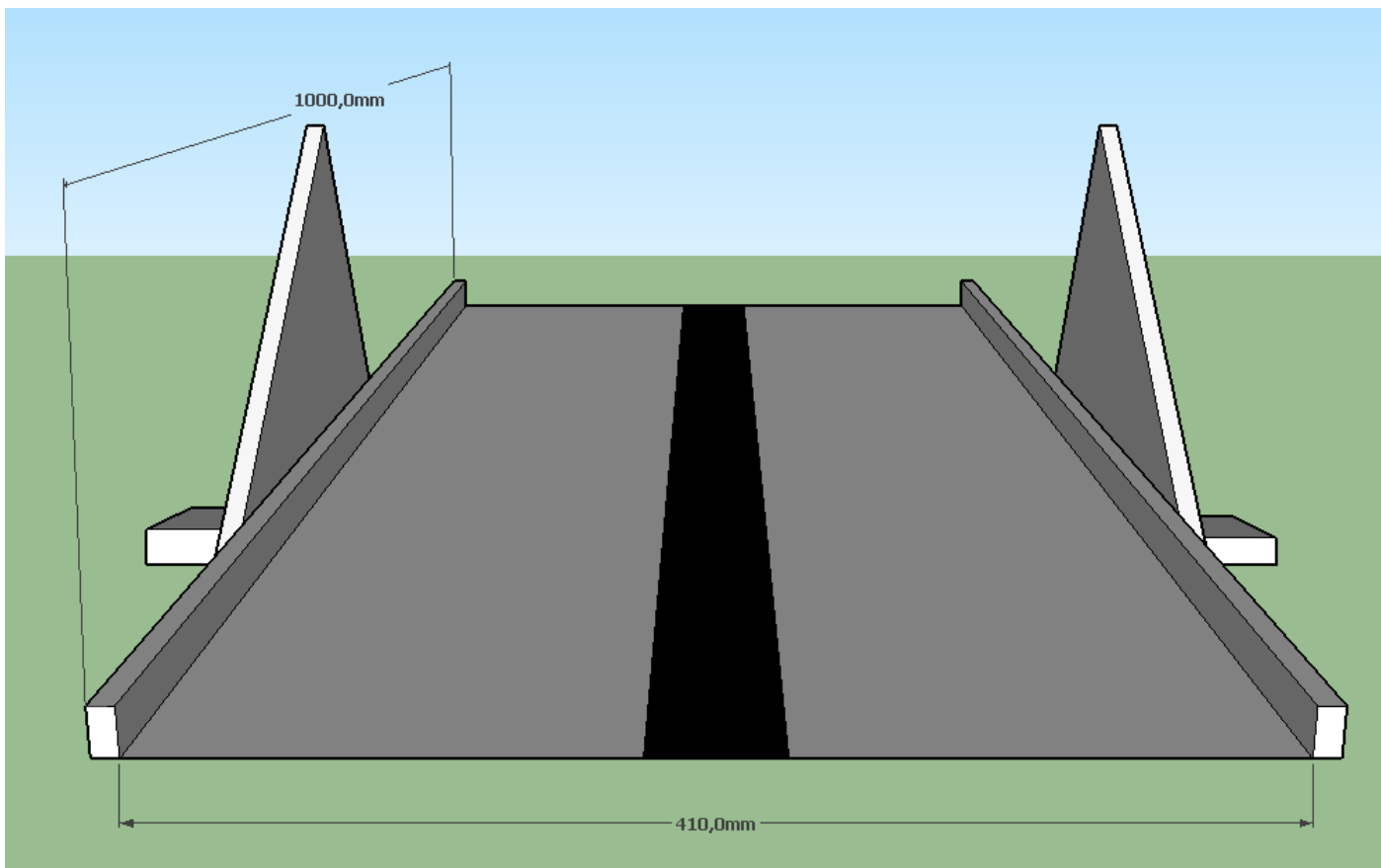

Back view of the bascule bridge

Challenge 2 : Flat racing

The challenge consists in running a minimum of 4,5 meters and a maximum of 5 meters on a flat board, and in a direct line.

No tracks are materialized.

The mobile is placed on the start zone, and at the start signal, it surges forward. It has to stop in the zone of the last 50 cm after opening the two doors materializing the end line. The doors are fixed on hinges and above the ground from 1cm.

The timing counted is the one between the start and the immobilization of the mobile. The board size is 1 meter large.

Maximum size for the mobile

Width : 20 cm maximum

Length : 20 cm maximum

Height : 30 cm maximum

Path board

At the start, the 2 doors are closed.

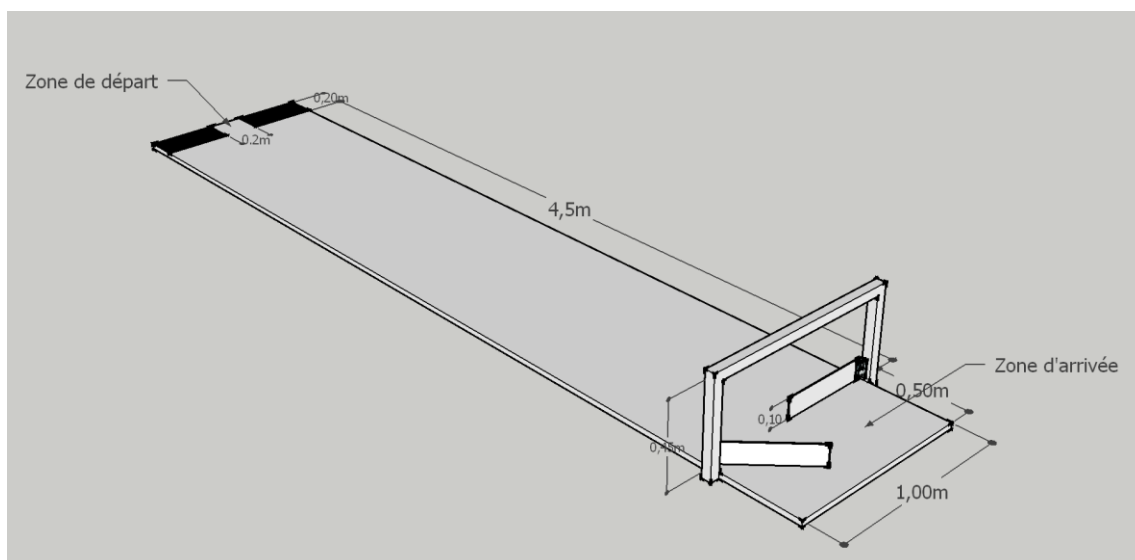

Perspective view - challenge 2

Article 3. Conduct of the competition

The competition will be held in 3 phases :

1. Accreditation phase

Verification of the size of the mobile and of the presence of the mandatory equipments. Submission of the technical files.

2. Timing phase

The teams will be allowed 5 timed trials. The mobile succeeding at least once will be selected and ranked. Only the best time of each mobile will be selected.

3. Elimination games phase.

Article 4. Organization

- Each team will have to be present at their allotted schedule time, as indicated by the jury.
- A digital or paper file will have to be produced at the start of the accreditation phase. In this file, we will have to find the different phases of conception and realization of the mobile, with the technical solutions researched and adopted.
- The technical files will be read by the jury and complementary informations may be asked to each team if the jury deemed it necessary. In the event of absence of the technical file, the mobile will be given a penalty.
- Only 2 participants will be accepted on the tracks.
- The whole team will be penalized in the eventuality of the mobile going out of the board.
- The mobile will be set at the starting point and could not be pushed to start.
- The jury's decisions can't be objected under penalty of forfait.
- The organisation team reserve the right to to modify the rules depending on the requirements for a successful conduct of the competition.

Article. 5 Prizes

A podium will be provided for each track and a special « design » prize will be awarded.

More informations on the project

On the school website Lycée Français Victor-Hugo

<https://www.lfvh.net/robots-en-piste/>

On the website AEFÉ

<https://www.aefe.fr/vie-du-reseau/toute-lactualite/la-robotique-tout-un-programme-concours-propose-par-le-lycee-francais-victor-hugo-de-francfort>

Follow us on Facebook

<https://www.facebook.com/LaRobotiqueToutUnProgramme/>

2023 Competition in the news

Lepetitjournal.com

<https://lepetitjournal.com/francfort/actualites/edition-2023-concours-robotique-lycee-francais-francfort-362681>

Frankfurter Allgemeine Zeitung

<https://www.faz.net/aktuell/technik-motor/technik/frankfurt-spektakulaeres-rennen-mit-selbst-gebauten-roboterautos-18919861.html>

Pre-registration file for the competition

« La robotique, tout un programme »

Wednesday, May 22th 2024

School :

Address :

.....

City + zip code :

Country :

Telephone :

Email :

One teacher can register several teams of students and chose for each team a different challenge.

Professor(s) Manager(s)	Teacher email	Grade	Number of students for each robot	Challenge choice (<i>cross out the unnecessary mention</i>)
				Challenge 1 Challenge 2
				Challenge 1 Challenge 2
				Challenge 1 Challenge 2
				Challenge 1 Challenge 2
				Challenge 1 Challenge 2

Hosted by families of the school : yes / no

Pre-registrations will be available:

You can send this file at the following email adress: christophe.bouvet@lfvh.net